

PROCESS MONITOR

AS-201

* Fullscale Adjustable



■ DC Voltage Measurement

Model Code	Range	Display Adjustable	Input Impedance	Input Protection
AS-201-1V	1~5V	0-100~1999	1MΩ	±250V
AS-201-2V	0~5V	0-100~1999	1MΩ	±250V
AS-201-3V	0~10V	0-100~1999	1MΩ	±250V

Accuracy: ±0.1% rdg ±2 digit (23°C ±5°C)

■ Specifications

Input Configuration:	Single Ended
Input Bias Current:	2nA(Typ.)
Conversion Rate:	2.5/sec
Normal Mode Rejection:	40dB Typ. (50/60Hz)
Temperature Coefficient:	±0.1 digit (Typ.)/°C ±0.3 digit (Max.)/°C
Display:	LED, 10.2mm 3 1/2 digit
Polarity:	1V Range:When input less than 1V, a "-" is displayed automatically. 2V, 3V Range:When input less than 0V, a "-" is displayed automatically.
Decimal Point:	Settable to any digit position
Overrange Indication:	When input exceeds the maximum display, 1999 flashes
Full-scale Adjustment:	100~1999
External Hold:	Negative 0V or Short
Power Supply:	DC 5V±5% 70mA (Typ.)
Operating Temperature:	0~50°C, 35 to 85%RH
Power Consumption:	350mW
Dimensions:	24(H) × 48(W) × 73(D)mm DIN Size
Weight:	40g
Dielectric Strength:	Between Input(Lo) and Mounted panel, AC1500V/1 min.
Insulation Resistance:	DC500V 100MΩ or more at above terminals

■ Features

- Adjustable full scale
- Bright LED 10.2mm
- Din size 24(H) × 48(W)
- 1-5V, 0-5V, 0-10V measurement
- Power supply DC5V (NO-ISOLATED)

■ Ordering Code

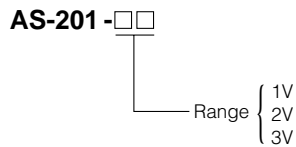

■ Dimensions

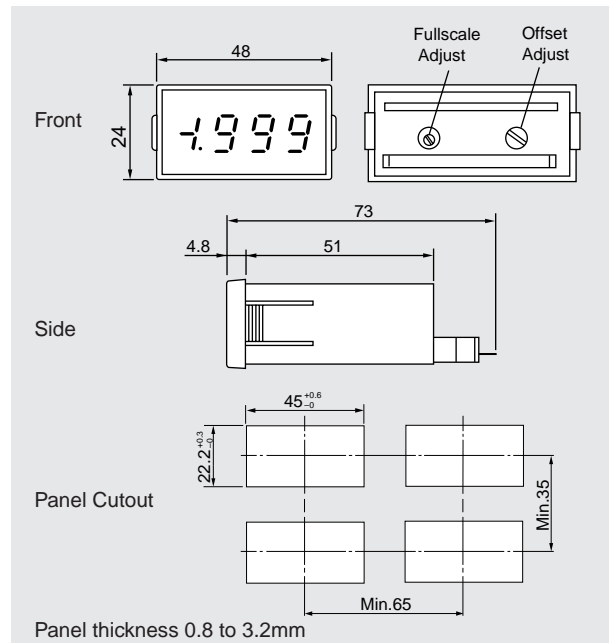

■ Connection Diagram

