

SETPOINT COMPARATOR

AM-147

* RS232C output



■ DC Voltage Measurement

Input	Range	Measuring Range	Display Adjustable	Input Impedance	Input Protection
DV	11	±99.9mV	Offset	100MΩ	±250V
	12	±999.9V		100MΩ	±250V
	13	±9.999V	±9999	1MΩ	±250V
	14	±99.99V	Fullscale	10MΩ	±500V
	15	±700.0V		10MΩ	±700V
	IV	1 to 5V	±0 to 9999	1MΩ	±250V

Accuracy: ±(0.03% of rdg + 2 digit)(23°C±5°C 45 to 75% RH)

■ DC Current Measurement

Input	Range	Measuring Range	Display Adjustable	Internal Resistance	Input Protection
DA	23	±9.999mA	Offset	10Ω	±150mA
	24	±99.99mA		1Ω	±500mA
	25	±999.9mA	Fullscale	0.1Ω	±3A
	2A	4 to 20mA		10Ω	±150mA

Accuracy: ±(0.1% of rdg + 2 digit)(23°C±5°C 45 to 75% RH)
±(0.3% rdg + 2 digit) for 25 range

■ General specifications

● Measurement block

Input configuration:	Single ended
Operation method:	Dual slope
Conversion rate:	12.5 time/sec (50 Hz), 15 time/sec (60 Hz)
Noise rejection ratio:	NMR more than 50 dB (50/60 Hz)
Temp. coefficient:	±(0.005% of rdg + 0.3 digit)/°C
Display:	Red LED, 14.2 mm height Green LED, 8 mm height for setpoint
Polarity display:	Automatic "-" display when the computation result is minus
Overrange warning:	When input exceeds the maximum display, display 0L or -0L
Maximum display:	0 to ±9999 (4 digit)
Decimal poin:	Settable to any digit position (by front sheet switch)
Zero display:	Leading zero suppression

● External control block

Hold:	Shorted COM terminal and S/H terminal or level "0"
Start:	Shorted COM terminal and S/H terminal or level "1"
Digital zero:	Shorted COM terminal and DZ terminal or level "0" (displayed zero and that value is stored)
Peak hold	
Valley hold:	Shorted COM terminal and PH terminal or level "0"
Peak Valley hold	
Pattern selection:	Any one of 8 patterns is settable in combination of COM terminal and P.SEL terminal 0, 1 and 2 Level "0" : 0 to 1.5V Level "1" : 3.5 to 5 V Input current : less than -2 mA

● Comparison block

Control method:	Computation by microcomputer
Setting range:	-9999 to 0 to +9999 (Including polarity)
Setting condition:	

■ Features

- Conversion rate 12.5times/sec(50Hz) or 15times/sec(60Hz)
- Four setpoint(Can display two setpoint)
- Multiple range
- Scaling value and setting value stored 8 pattern
- Peak hold, Valley hold, Peak-valley hold, Digital zero, Moving average(standard)
- Power supply for sensor 24VDC 40mA
- Direct setting function
- Power supply 90 to 264VAC

Comparison condition:

Comparison condition	Comparison result
High high limit set value < Measured value	HH
High limit set value < Measured value	HI
High high limit set value < Low low limit set value ≥ Measured value ≥	GO
High limit set value < Low limit set value	LO
Measured value < Low low limit set value	LL

Comparison relay output:	Contact capacity 250 V AC 0.2 A Resistive load 120 V AC 0.5 A Resistive load 28 V DC 1 A Resistive load
Photo coupler output: (NPN)	Voltage = Max. 30 V Current = Max. 50 mA Saturation voltage = less than 1.2 V at 50 mA
Hysteresis:	1 to 999 digit for each set point
External control:	Relay reset Shorted COM terminal and R.RE terminal or level "0" Level "0" : 0 to 1.5 V Level "1" : 3.5 to 5 V Input current : less than -2 mA

● Common block

Memory backup:	EEPROM (rewrite 100,000 times) back up 10 years
Operating temp:	0 to 50°C 35 to 85% RH (No condensation)
Storage temp:	-10 to 70°C less than 60% RH
Power supply:	90 to 264 V AC (50 Hz/60 Hz)
Power consumption:	Approx 10 VA typ (at 100 V AC)
Dimensions:	96 mm(W) X 348 mm(H) X 3148 mm(D) DIN size
Weight (unit only):	Approx 450 g
Dielectric strength:	Input/COM, EXC (0 V), comparative output, 500 V DC/1 min. Input/COM of each output (BCD:FD.COM, ANALOG:-, RS-232C:SG, RS-485) 500 V DC/1 min. Power supply terminal/input terminal, COM, EXC (0 V), case, comparative output, 1500 V AC/1 min. Power supply terminal/COM of each output (BCD:D.COM, ANALOG:-, RS-232C:SG, RS-485) 1500 V AC/1 min.
Insulation resistance:	500 V DC more than 100 MΩ at the above terminals
Dielectric noise:	Power supply terminal normal/common mode ±1500 V
Power supply for sensor:	24 V DC±10% 40 mA ripple 100 mVp-p
Accessories:	Instruction manual quick manual, setting list, unit label, terminal cover

SETPOINT COMPARATOR

AM-211A

*One Setpoint

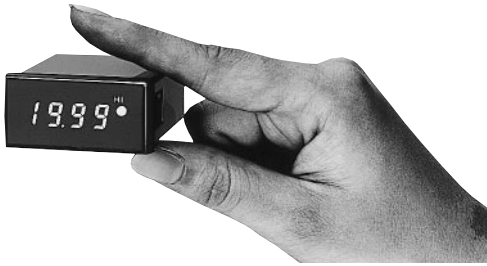

■ DC Voltage Measurement

Model	Range	Maximum Resolution	Input Resistance	Input Protection
AM-211-11	±199.9mV	100μV	100MΩ	±250V
AM-211-12	±1.999V	1mV	100MΩ	±250V
AM-211-13	±19.99V	10mV	10MΩ	±250V
AM-211-14	±199.9V	100mV	10MΩ	±250V

Accuracy: ±0.1% rdg. ±1 digit (23°C ±5°C)

■ Specifications

Input configuration:	Single Ended
Input Bias Current:	Less than 120PA
Conversion Rate:	2.5/sec
Normal Mode Rejection:	40dB(Typ.)(50/60Hz)
Zero Stability:	Automatic Zero Adjustment
Display:	LED, 8mm 3 1/2 digits
Polarity:	A "-" is displayed automatically
Decimal Point:	Settable to any digit position
Overrange Indication:	When input exceeds the maximum display, 1999 flashes.
Control system:	Analog comparator system
Setting Range:	0~+1999 or -1999
Comparative Condition:	Indication ≥ Set-point (LED ON)
Relay Contact Capacity:	250V AC 0.1A Resistive load 120V AC 0.5A Resistive load 28V DC 1A Resistive load
External Control:	Reset: When TTL level "0" or reset and common terminal (Short) comparison value hold Start: Contact signal (Open)
Hysteresis:	Approx. 20 digits (23°C ±5°C)
Power Supply:	DC 5V ±5%
Operating Temperature:	0~50°C, 35 to 85%RH
Power Consumption:	Approx. 500mW
Dimensions:	24(H) × 48(W) × 73(D)mm DIN Size
Weight:	Approx. 60g
Dielectric Strength:	Between power supply (Lo) terminal and relay output, DC 500V/min. Between power supply terminal and case, AC 1500V/1 min.
Insulation Resistance:	DC 500V 100MΩ, power supply (Lo) and relay output.

■ Features

- Analog comparator
- 1 set-point
- 200mV~200V Measurement
- Bright LED 8mm (Red)
- DC 5V (Non-Isolated)

■ Ordering Code

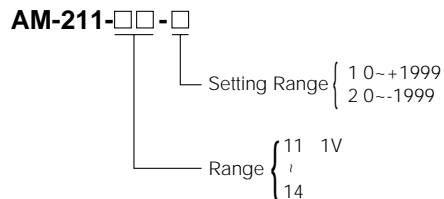

■ Dimensions

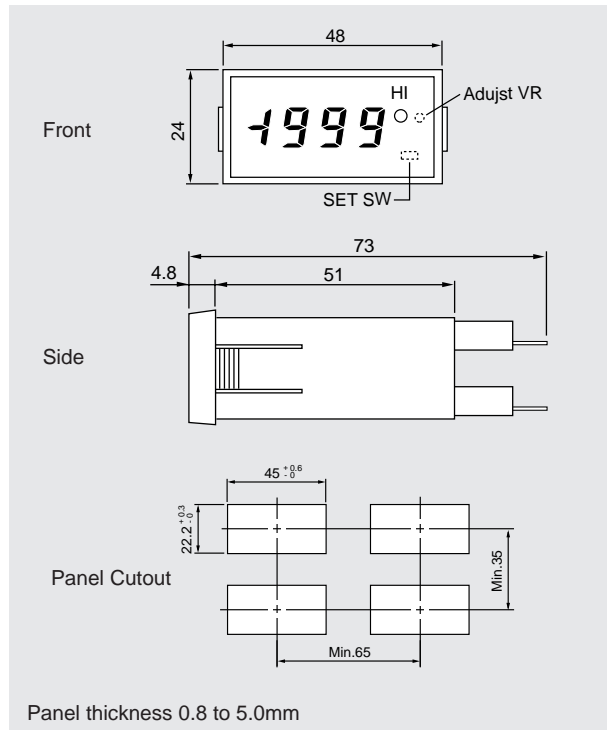

■ Connection Diagram

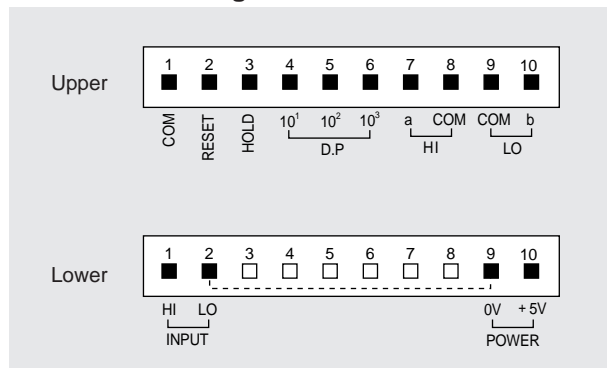

SETPOINT COMPARATOR

AM-213



■ Features

- NEMA 4 front panel (IP66)
- Excitation power supply DC24V
- Analog output (4 to 20mA) option
- HI and LO setpoints
- 1/32 DIN size

■ DC Voltage Measurement

Model	Range	Display	Input Impedance	Input Protection
AM-213-11	± 99.99mV	OFFSET ± 9999	100MΩ	± 250V
AM-213-12	± 999.9mV		100MΩ	± 250V
AM-213-13	± 9.999V	FULLSCALE ± 9999	1MΩ	± 250V
AM-213-1V	1 to 5 V		1MΩ	± 250V

Accuracy : ± (0.03% of rdg +2 digit) (23°C ± 5°C 35 to 85%RH)

■ DC Current Measurement

Model	Range	Display	Input Impedance	Input Protection
AM-213-2A	4 to 20mA	OFFSET ± 9999 FULLSCALE ± 9999	50Ω	± 60mA

Accuracy : ± (0.1% of rdg +2 digit) (23°C ± 5°C 35 to 85%RH)
Accuracy is less than 1 (FSC-OFc) / (FIN-OIN)

■ Specifications

● Measuring Section

Input configuration: Single ended
 Conversion rate: 12.5 times/sec(50Hz), 15 times/sec(60Hz)
 Noise rejection ratio: NMR50dB or more (50/60Hz)
 Display: Red LED, 8mm height
 Polarity display: Automatic "-" display when the computation result is minus
 Overrange warning: When input exceeds the maximum display, display OL or -OL
 Maximum display: ± 9999
 Decimal point: Settable to any digit position
 Zero display: Leading zero suppression

● Common Section

Memory backup: EEPROM (rewrite 100,000 times)
 Operating temp.: 0 to 50°C 35 to 85%RH
 Storage temp.: -10 to 70°C (less than 60%RH)
 Power supply: DC24V ± 20%
 Power consumption: 85mA (TYP) at DC24V
 Dimensions: 48mm(W) × 24mm(H) × 388mm(D)
 Weight: approx.100g (unit only)
 Dielectric strength: Input terminal (LO) and comparator output, ANALOG (-), DC500V/min.
 Power supply (OV) and input (LO), comparator output, ANALOG (-), case, DC500V/min.
 Input terminal (LO) and case AC1500V/min.
 Insulation resistance: DC500V more than 100MΩ at the above terminals
 Excitation supply: DC24V ± 10% 25mA ripple less than 200mVp-p
 Accessories: Instruction manual, rubber paking, terminal

■ Output Specification

● Analog Output (isolated input LO)

Model	Range	Display	Input Impedance	Input Protection
AM-213-2A	4 to 20mA	OFFSET ± 9999 FULLSCALE ± 9999	50Ω	± 60mA

Can adjust analog output to meet display.
 Ripple for resistive load 250Ω, 20mA

■ Ordering Code

AM-213 - □ □ □ □

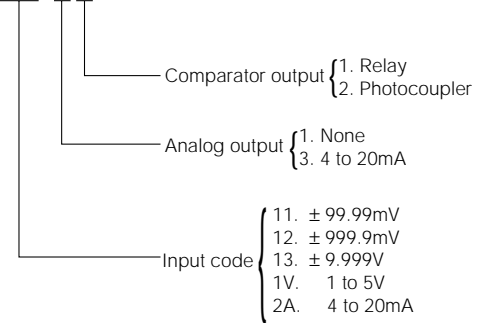

■ Dimensions

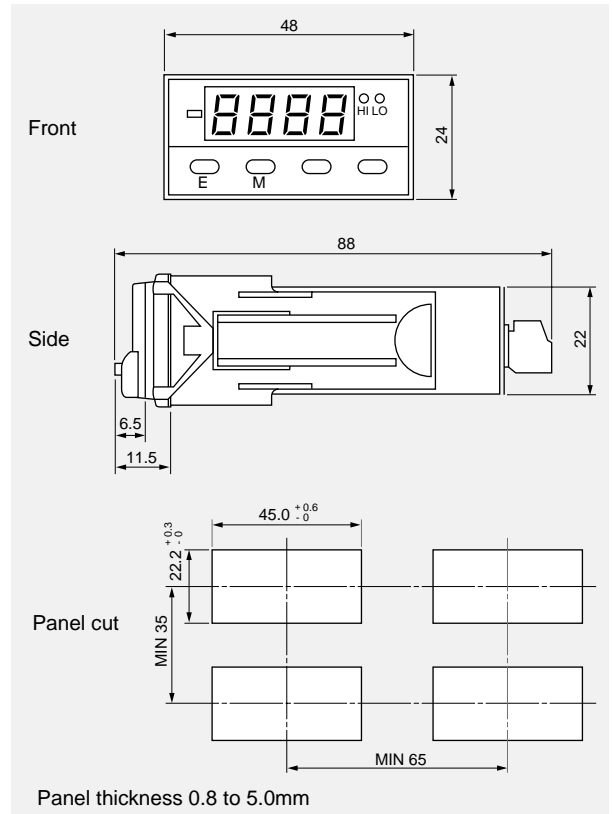

■ Connection Diagram

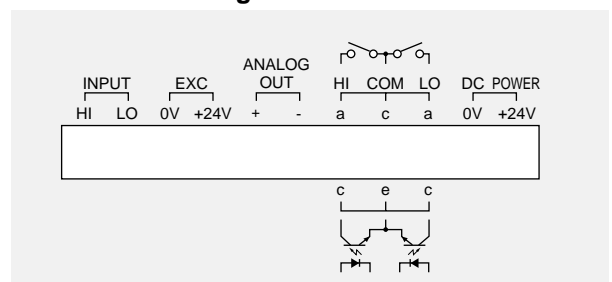

SETPOINT COMPARATOR

AM-749

■ Optional specifications

•BCD output [Isolated from input(LO)]

Measured date: Negative logic
NPN open-collector output

Polarity signal: Transistor "ON" at minus input

OVER signal: Transistor "ON" at "OVER" input

Printing command signal: Transistor "ON" for approx. 10ms at the end of measurement

ENABLE: All date output transistors are turned "OFF" when ENABLE and digital common terminals are shorted or input level is set at "0".
"0" level: Less than 1.5V
"1" level: 3 to 30V
Input current: Less than -5mA

Transistor output capacity: Applied voltage, 30V max. Current, 10mA max.
Output saturation voltage: Less than 1.2V at 10mA
*TTL output is also available.

•RS-232C [Isolated from input(LO)]

Electrical characteristics: Conforming to EIA RS-232C

Communication method: Full duplex

Synchronous method: Start and stop

Transmission speed: 2400/4800/9600/19200 bps

Start bit: 1 bit

Data length: 7 bits

Error detection: Even parity

Stop bit: 2 bits

Character code: ASC II

Transmission control: No protocol

•RS-485 [Isolated from input(LO)]

Electrical characteristics: Conforming to EIA RS-485

Synchronous method: Start and stop

Communication method: 2-wire system half-duplex (Polling and selecting)

Transmission speed: 2400/4800/9600/19200 bps

Start bit: 1 bit

Date length: 7 bits

Error detection: Even parity
BCC(Block check character)check sum

Stop bit: 2 bits

Character code: ASC II

Transmission control: No protocol

Signal name used:

Signal name	Signal	Signal direction
Non-reversible output	+	Input/output
Reversible output	-	Input/output

No. of connectable meters: Up to 31 meters
Line length: Up to 500m in total

•Analog output [Isolated from input(LO)]

Any display range to output analog signal can be set.

Resolution: 16 bits

Output response: Less 0.5s

Output	Resistive load	Accuracy (23°C ±5°C)	Ripple
1 to 5V	More than 10kΩ	±0.5% F.S	50mVp-p
4 to 20mA	0 to 600Ω	±0.5% F.S	-

Moving average: Digital filter function

Fixed zero: 10⁹ -digit is fixed to "0" for display

Display blanking: Blanking of LEDs on main, monitor/sub-display units.

Tracking zero: (Only for RS-232C and RS-485 meters)
Zero-point shift is digitally, automatically corrected. Activated when digital zero function becomes valid.

■ Ordering Code

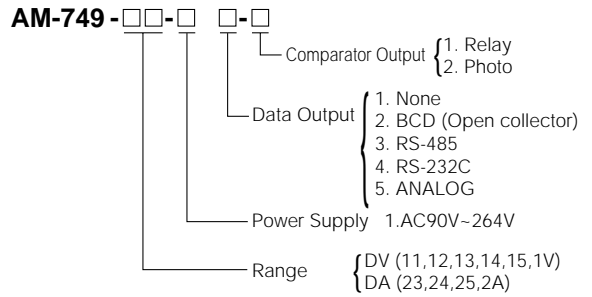

■ Dimensions

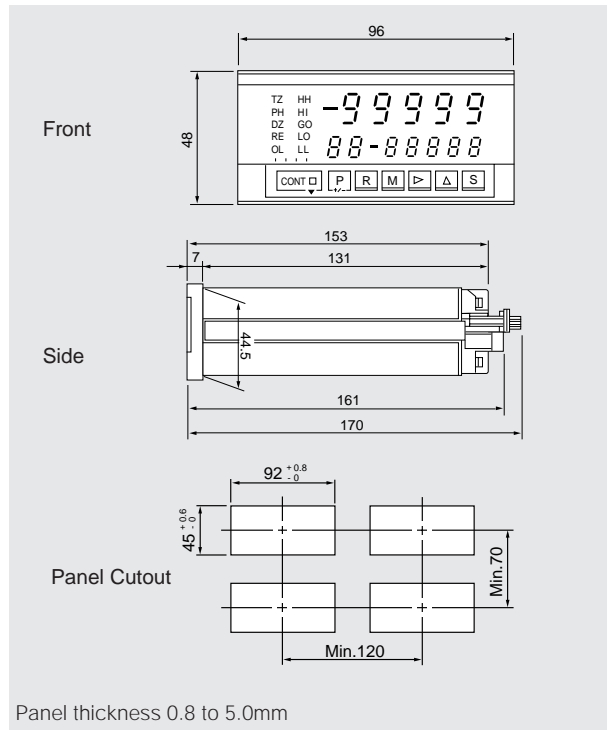

■ Connection Diagram

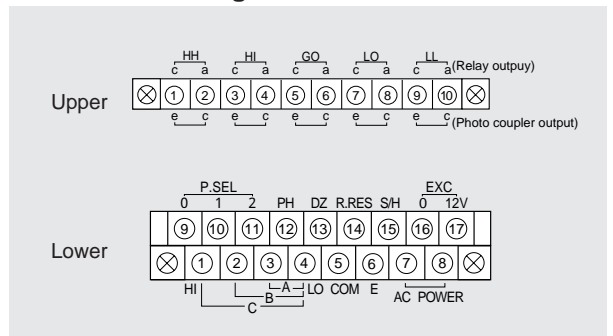

■ Connection Diagram

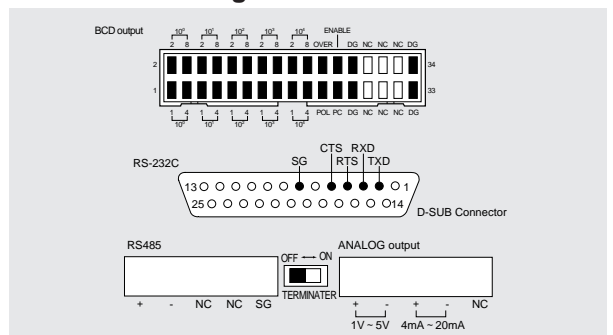

SETPOINT COMPARATOR

AMH-752

*4000 Time/sec



DC Voltage Measurement

Model	Range	Display Adjustable	Input Impedance	Input Protection
AMH-752-11	±199.9mV	OFFSET ±1999	100MΩ	±250V
AMH-752-12	±1.999V	FULLSCALE ±1999	10MΩ	±500V
AMH-752-13	±19.99V			
AMH-752-14	±199.9V			

Accuracy: ±0.1% ±2 digit(23°C±5°C)(a≤1)(Normal Speed Mode)
±0.1% ±4 digit(23°C±5°C)(a≤1)(High Speed Mode)

DC Current Measurement

Model	Range	Display Adjustable	Internal Resistance	Input Protection
AMH-752-21	±199.9μA	OFFSET ±1999	1kΩ	±10mA
AMH-752-22	±1.999mA		100Ω	±50mA
AMH-752-23	±19.99mA	FULLSCALE ±1999	10Ω	±150mA
AMH-752-24	±199.9mA		1Ω	±500mA
AMH-752-25	±1.999A		0.1Ω	±3A

Accuracy: ±0.2% rdg. ±2 digit(23°C±5°C)(a≤1) } Normal Speed Mode
±0.3% rdg. ±2 digit only for AMH-75X-25 }
±0.2% rdg. ±4 digit(23°C±5°C)(a≤1) } High Speed Mode
±0.3% rdg. ±4 digit only for AMH-75X-25 }

1-5V Measurement

Model	Range	Display Adjustable	Input Impedance	Input Protection
AMH-752-1V	1-5V	OFFSET ±1999 FULLSCALE ±1999	1MΩ	±250V

Accuracy: ±0.1% rdg. ±3digit (23°C±5°C) (a≤1) (Normal Speed Mode)
±0.1% rdg. ±5digit (23°C±5°C) (a≤1) (High Speed Mode)

4-20mA Measurement

Model	Range	Display Adjustable	Input Resistance	Input Protection
AMH-752-2A	4-20mA	OFFSET ±1999 FULLSCALE ±1999	10Ω	±150mA

Accuracy: ±0.1% ±3 digit (23°C±5°C) (a≤1) (Normal Speed Mode)
±0.1% ±5 digit (23°C±5°C) (a≤1) (High Speed Mode)

*a=Scaling Coefficient

Specifications

- Measuring function: Specify one type from among DC voltage, DC current and instrumentation input signal measurements.
- Operation method: Successive approximation type
- No. of input points: 2(A ch. and B ch.)ch.→channel
- Input selection: A, B, A+B, A-B, A & B, and $\{(A-B)/|B|\} \times 100$
- Input circuit: Single-ended type
- Input bias current: 1nA(TYP)
- Conversion Rate: 1.25 times/sec to 4000 times/sec(For 1 ch.)
0.652 times/sec to 2000 times/sec(For 2 ch.)
- Display: LED
Measured-value display unit character height; 10.0mm(red)
Monitor character height ; 8mm(green)
- Display speed: 12.5 times/sec(Only in the normal speed mode)
Display in the high-speed mode ; Displayed only during hold.

Mode	High Speed Mode			
No.	1	2	3	4
Conversion Rate (1ch) per sec.	4000 (1)	2000 (2)	1333.3 (3)	1000 (4)
Conversion Rate (2ch) per sec.	2000	1000	666.7	500

Features

- Conversion Rate 1000/sec~4000/sec
- 2 input computation(A, B)
- 4-sets/4-pattern Setting
- Peak, Valley, Peak-Valley hold(Optional)
- Digital zero(Optional)
- RS-232C Communication(Optional)
- BCD, ANALOG Output(Optional)
- Bright LED 10mm(Red)

Mode	Normal Speed Mode					
No.	5	6	7	8	9	10
Conversion Rate (1ch) per sec.	1000 (5)	500 (10)	250 (20)	125 (40)	100 (50)	50 (100)
Conversion Rate (2ch) per sec.	500	250	125	62.5	50	25

Mode	Normal Speed Mode					
No.	11	12	13	14	15	16
Conversion Rate (1ch) per sec.	25 (200)	12.5 (400)	10 (500)	5 (1000)	2.5 (2000)	1.25 (4000)
Conversion Rate (2ch) per sec.	12.5	6.25	5	2.5	1.25	0.625

() Average time

- Polarity display: Automatic "-" display when the computation result is minus
- Overrange warning: Overflow display when input signal exceeds measuring range
LED(red)flashes.(Display:Value just before overflow occurs)
- Zero display: Leading "zero" suppression
- Decimal point: Settable to any position(by dip switch at the front).
- Maximum display: ±1999
- External control: Start/hold(start hold A type)
Start→Start terminal open(or 5 V)
Hold→Shorting between digital common and hold terminals(or 0 V)
*:Sample hold(start hold B type)
Only one measurement is performed from rise of positive or negative pulse of more than 500μs and the result is out-put.
*:Digital zero
Function of making the mechanical initial value such as of pressure sensor, potentiometer, etc.
to zero electrically. By shorting between the digital common and digital zero (for A ch. or B ch.) terminals, or at 0V:The displayed value just after the above shorting made or voltage is set to 0 V is changed to "zero" and the value at that time is stored.
(A ch. and B ch. can be independently controlled.)
*:Peak hold, valley hold and peak valley hold
•Peak hold: Display of maximum value measured
•Valley hold:Display of minimum value measured
•Peak valley hold: Display of the difference between maximum and minimum value measured
The respective display function works with the common and above terminals shorted or at 0 V.
(However, only display is made, and comparison output is always in accordance with voltage or current value applied between input Hi and Lo.)
*:Settable on the sheet key at the front.

SETPOINT COMPARATOR

AMH-752

■ Comparison Section

1. Control method: Computation by microcomputer
2. Setting range: High/low limit setting including polarity(2/4-step setting)-1999 to 0 to +1999

3. Comparison conditions (display):

Comparison condition	Comparison result
	AMH-752
Measured value > High/high limit set-value	HH (HI)
High/high limit set-value - Measured-value > High limit set-value	HI
High limit set-value - Measured-value < Low limit set-value	GO
Low limit set-value < Measured-value < Low/low limit set-value	LO
Low/low limit set-value > Measured-value	(LO) LL

4. Comparison display: As a comparison result, the respective light emitting diode lights.

5. Comparison relay output:

HH, HI, GO, LO, and LL (1 "a", each)

6. Relay output cycle:

Approx. 12.5ms

At 1ch. input

- Conversion Rate: When the speed is slower than 80 times/sec, output for each sampling.
Conversion Rate: When the speed is faster than 80 times/sec, outputs the result at that time at about 12.5 msec intervals. (Excluded at start/hold.)

7. Relay contact capacity: 250V AC, 0.1A Resistive load

120V AC, 0.5A Resistive load

28V DC, 1A Resistive load

8. Photo-Coupler output: Sink current; 20mA max. (less than 30 V) (NPN open-collector)

9. Photo-Coupler output cycle:

Approx. 250µs at the sampling speed of 4000 times/sec for 1ch. input
For others; Depending on each sampling speed

10. Hysteresis:

Settable from 1 to 999 digits for each comparison set-value.

11. External control:

Comparison output reset with the reset and digital common terminals shorted (or at 0 V)

■ Common Specifications

1. Memory backup: Set data can be reserved for about 10 years using EEPROM.
2. Operating temperature and humidity: 0 to 50°C, 35 to 85% RH
3. Power supply: 90 to 132V AC 50/60Hz
180 to 264V AC 50/60Hz (Internal jumper wire selection)
4. Power consumption: Approx. 5VA (at 100V)
5. Dimensions: 48mm(H) × 96mm(W) × 158mm(D), DIN size
6. Dielectric strength: Between input and grounding(E) terminals, 500V DC
Between input and digital common/relay output/transistors output; 500V DC, each
Between power supply terminal and input terminal/grounding(E)/digital common/relay output/transistor output; 1 min at 1500V AC, each.
7. Insulation resistance: Between each terminal described above, more than 100MΩ at 500V DC
8. Weight: Approx. 600g (mainframe)
9. Accessories: Input/output screw terminals, 2 pcs.
Instruction manual
Data output plug (Amphenol 57-30360)
10. Others: For unit display, contact us.

■ Optional Specifications

1. BCD output: Tri-state, Parallel BCD output, Fan out 2 (TTL level)
Polarity output → At minus value; "1"
Overflow output → At overflow; "1"
P.C output: At the end of A/D conversion, plus pulse in approx. 500µs width
*Only in the normal speed mode
Bidirectional (Full duplex)
2. RS-232C: (Conformance)
3. Analog output: Output voltage; ±0 to 2.5V
Resolution: 0.25mV/digit
Accuracy: 0.5% FS (23°C ±5°C)
External resistance: More than 20kΩ
Overvoltage: Approx. ±3.5V, less than 5V
*Any of high speed and normal speed modes is available.
4. Absolute value display comparison: Function of outputting absolute value regardless input single polarity

■ Ordering Code

AMH-752-□□-□□-□

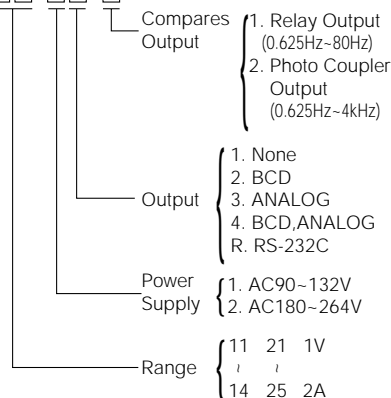

SETPOINT COMPARATOR

AMH-752

■ Dimensions

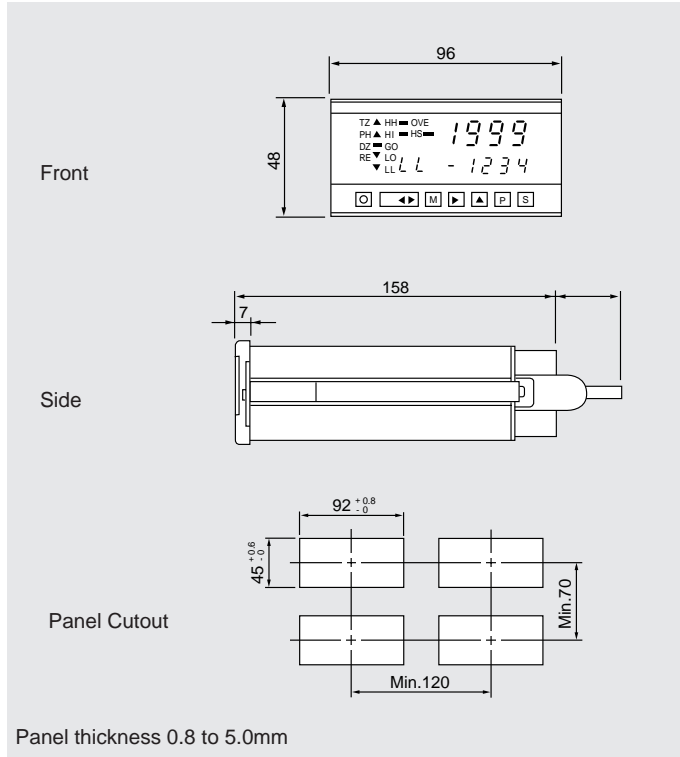

■ Data Output

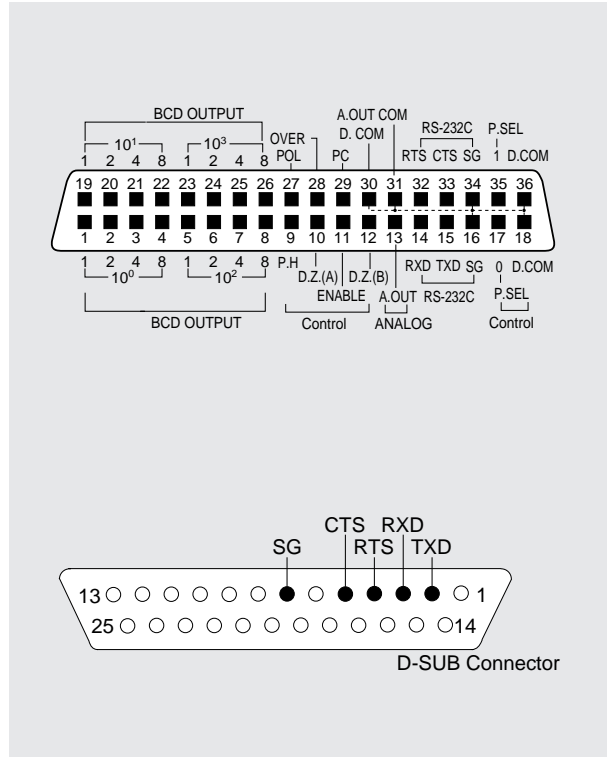

■ Connection Diagram

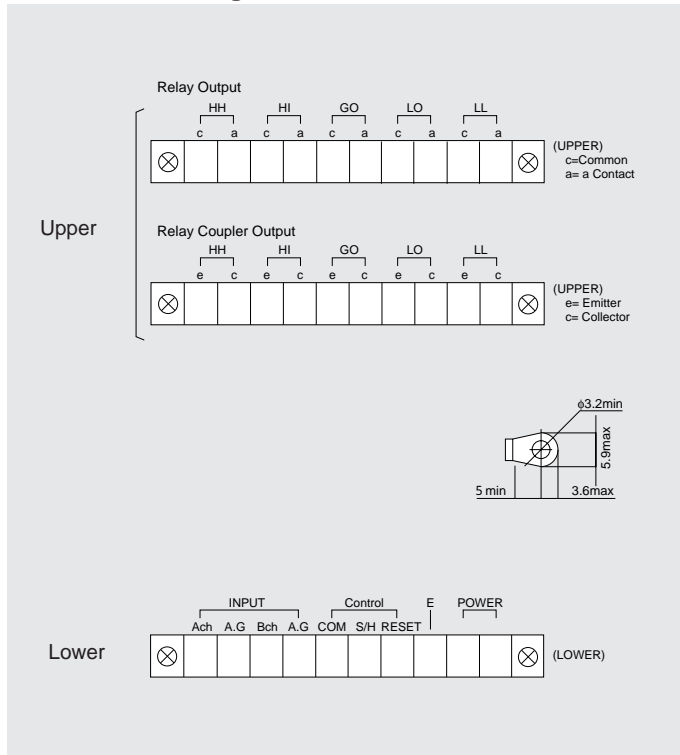

SETPOINT COMPARATOR

AMH-762

*High Conversion rate

1000times/sec (Normal speed mode)

4000times/sec (High speed mode)



■ DC Voltage Measurement

Model	Range	Display Adjustment	Input Impedance	Input Protection
AMH-762-13	±9.999V	Offset ±10000 Fullscale ±0 to 10000	1M	±250V

Accuracy:±0.1% FS (23°C±5°C)

■ 1 to 5V Measurement

Model	Range	Display Adjustment	Input Impedance	Input Protection
AMH-762-1V	1 to 5V	Offset ±10000 Fullscale ±0 to 10000	1M	±250V

Accuracy:±0.1% FS (23°C±5°C)

■ 4 to 20mA Measurement

Model	Range	Display Adjustment	Internal Resistance	Input Protection
AMH-762-2A	4 to 20mA	Offset ±10000 Fullscale ±0 to 10000	50	±70mA

Accuracy:±0.1% FS (23°C±5°C)

Condition for accuracy, (FSC-OFS)/(FIN-OIN) is less than 1

■ Specifications

• Measuring Section

Input Configuration: Single Ended
 Operation Method: Successive approximation type
 No. of Input: A input and B input
 Conversion Rate : 0.5times to 4000times(only use one input)
 0.25times to 2000times(use two input)

Mode	High Speed Mode	
	No.	2
Conversion Rate (1ch) per sec.	4000	2000
Conversion Rate (2ch) per sec.	2000	1000

Mode	Normal Speed Mode						
	No.	4	8	10	20	40	100
Conversion Rate (1ch) per sec.	1000	500	400	200	100	50	40
Conversion Rate (2ch) per sec.	500	250	200	100	50	25	20

Mode	Normal Speed Mode							
	No.	200	400	800	1000	2000	4000	8000
Conversion Rate (1ch) per sec.	20	10	5	4	2	1	0.5	
Conversion Rate (2ch) per sec.	10	5	2.5	2	1	0.5	0.25	

■ Features

- High Conversion Rate, 1000times/sec (Normal speed mode)
4000times/sec (High speed mode)
- 2 inputs computation (A input, B input)
- Digital Zero, Peak Hold, Valley Hold, Peak-Valley Hold
- Available 8-pattern Setting for Scaling value and setpoints (Data Back-up EEPROM)
- Excitation Supply 24VDC 40mA
- RS-232C, RS-485 Output (Option)
- BCD, Analog Output (Option)
- Power Supply (90 to 264VAC)
- Bright LED, 10mm (Red)

Display: LED, 10mm high (Red)
8mm high (Green) for monitor

Display Speed: 1.25, 2.5, 12.5, 25times/sec for Normal speed mode

When pressed key of "C", appear display value for High speed mode

A "." is displayed automatically

Polarity : Overrange Indication: When input exceeds the maximum display, display OL and flash

±99999

Max. Display: Settable to any digit position

Decimal Point: Leading zero suppression

Zero Display: Hold ; Shorted D.COM and S/HA, S/HB

External Control: terminal or level "0"
Start; Open D.COM and S/HA, S/HB terminal or "1" level

Digital Zero; Shorted D.COM and

DZA, DZB terminal or level "0"

Peak Hold;

Valley Hold; Shorted D.COM and PH terminal or level "0"

Peak Valley Hold;(Compare the display value)
Selected either one

Pattern Select; Combination of D.COM and P.SEL terminal

Level "0"= 0 to +1.5V

Level "1"= +3.5 to 5V

Current= less than -5mA

*Not provided PH, DZA and DZB for RS-232C and RS-485 output

SETPOINT COMPARATOR

AMH-762

• Comparator Section

Control System: Microcomputer
 Setting Range: -99999 to +99999 with polarity
 Comparative Condition: High High setpoint < Indication →HH
 High setpoint < Indication →HI
 High setpoint ≥ Indication ≥ Low setpoint →GO
 High high setpoint ≥ Indication ≥ Low low setpoint]
 Low setpoint > Indication →LO
 Low low setpoint > Indication →LL

Relay Contact Capacity: 250VAC 0.2A Resistive load
 120VAC 0.5A Resistive load
 28VDC 1A Resistive load

Photo Coupler Output: Voltage=Max. 30V
 Current=Max. 20mA
 Saturation voltage=less than 1.2V at 20mA

Hysteresis: 1 to 9999 digit each setpoints
 External Control: Reset; Shorted D.COM and R.RE terminal or level "0"

• Common Section

Memory Back-up : EEPROM (Rewrite more than 100,000 times)
 back up 10 years
 Operating Temp: 0 to 50°C 35 to 85% RH
 Power Supply: 90 to 264VAC
 Power Consumption: Approx 10VA TYP. (at 100V)
 Dimensions: 48(H) × 96(W) × 161(D) mm DIN size
 Weight: Approx. 600g (unit only)
 Dielectric Strength: Input/earth, COM, Comparative output,
 DC500V/ 1 min.
 Input/D.COM of each output terminal,
 DC500V/1 min.
 Power supply/D.COM, case, comparative
 output, 1500VAC/1 min.

Insulation Resistance: 500VDC more than 100M ohms at the above
 terminals

Excitation Supply: 24VDC ±10% 40mA (Ripple less than 100mV
 p-p)

Accessories: Instruction manual

■ Output

● BCD data output (Isolated input (Lo))

• At Open collector (NPN)

Measured Data: Negative logic transistor "ON" at logic 1
 Polarity Signal: Transistor "ON" at minus input
 Over Signal: Transistor "ON" at overflow input
 Printing Command Signal: Transistor "ON" during a period at every
 measurement completion

Transistor Output Capacity:

Applied voltage, 30V max. current 10mA max.
 Saturated output voltage less than 1.2V at
 10mA
 *Available TTL output

● RS-485 (Isolated input (Lo))

Electrical Characteristics: Conforming to EIA RS-485
 Synchronous Method: Start and stop
 Communication Method: 2-wires system half-duplex (Polling and
 selecting)
 Transmission Speed: 2400/4800/9600/19200 bPS
 Start Bit: 1 bit
 Data Length: 7 bits
 Error Detection: Even parity (BCC)
 Stop Bit: 2 bits
 Character Code: ASCII code
 Transmission Control: No protocol
 Signal name used:

Signal name	Signal	Signal Direction
Non-reversible output	+	Input/output
Reversible output	-	Input/output

No. of Connectable Meter: Up to 31 meters
 Line Length: Up to 500m in total

● RS-232C (Isolated input (Lo))

Electrical Characteristics: Conforming to EIA RS-485
 Communication Method: Full duplex
 Synchronous Method: Start and Stop
 Transmission Speed: 2400/4600/9600/19200 bps
 Start Bit: 1 bit
 Data Length : 7 bits
 Error Detection: Even parity
 Stop Bit: 2 bits
 Character Code: ASCII code
 Transmission Control: No protocol

● Analog Output (Isolated input (Lo))

Output	Resistive load	Accuracy(23°C±5°C)
1 to 5V	More than 10K	±0.5% FS
4 to 20mA	0 to 500	±0.5% FS

■ Other Functions

Moving Average: Digital Filter function
 Fixed Zero: 10th digit is fixed to "0" for display
 Display Blanking: Blanking of LEDs on main and
 monitor display
 Tracking Zero: Zero point shift is digitally,
 automatically corrected.
 Activated when digital zero function
 becomes valid

SETPOINT COMPARATOR

AMH-762

Ordering Code

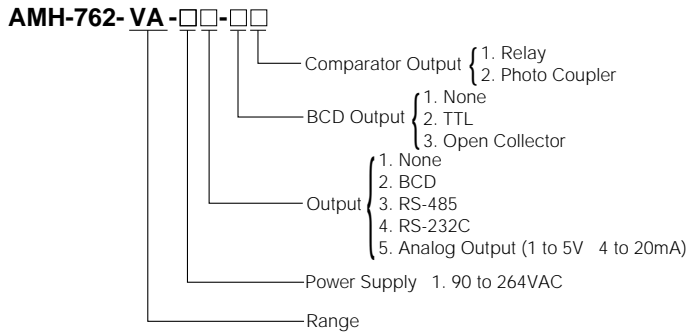

Dimensions

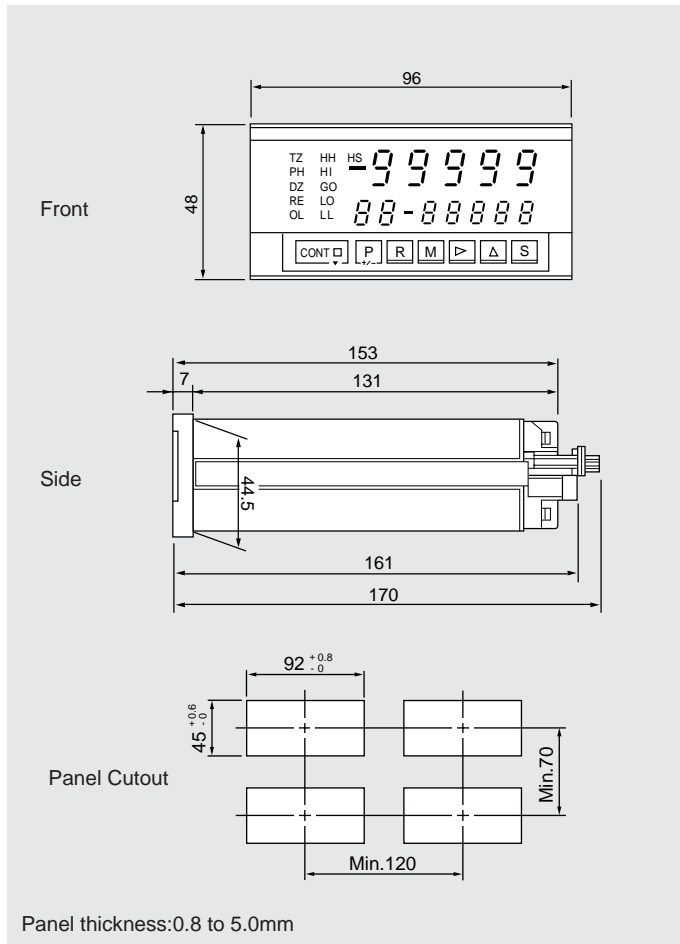

Connection Diagram

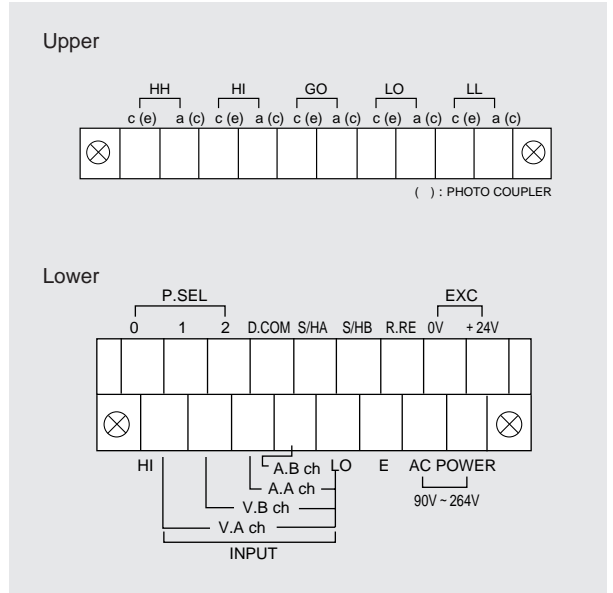

Connection Diagram

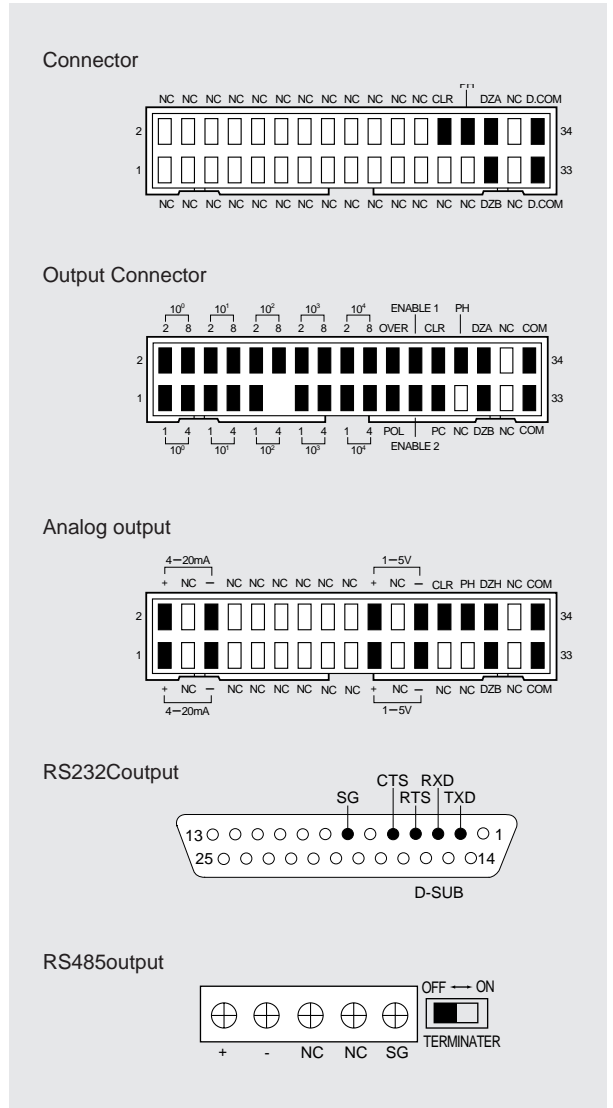

SETPOINT COMPARATOR

AM-342

*HH, HI, LO, LL, Setpoint



DC Voltage Measurement

Code	Range	Display Adjustable	Input Impedance	Input Protection
DV	11	±99.99mV	100MΩ	±250V
	12	±999.9mV		
	13	±9.999V	100MΩ	±250V
	14	±99.99V		
	15	±700.0V	10MΩ	±500V
	1V	1-5V		

Accuracy: ±0.03% rdg ±2 digit (23°C ±5°C)

DC Current Measurement

Code	Range	Display Adjustable	Internal Resistance	Input Protection
DA	23	±9.999mA	10Ω	±150mA
	24	±99.99mA	1Ω	±500mA
	25	±999.9mA	0.1Ω	±3A
	2A	4-20mA	±9999	10Ω

Accuracy: ±0.1% rdg ±2 digit (23°C ±5°C)
±0.3% rdg ±2 digit for only 25 range

AC Voltage Measurement (TRUE-RMS)

Code	Range	Display Adjustable	Input Impedance	Input Protection
AV	13	0-9.999V	1MΩ	300V
	14	0-99.99V		
	15	0-700.0V	10MΩ	700V

Accuracy: ±0.3% rdg ±5 digit (23°C ±5°C)

AC Current Measurement (TRUE-RMS)

Code	Range	Display Adjustable	Internal Resistance	Input Protection
AA	24	0-99.99mA	1Ω	500mA
	25	0-999.9mA	(CT)	10A
	26	0-5.000A	±9999	(CT)

Accuracy: ±0.5% rdg ±10 digit (23°C ±5°C)

Specifications

Input Configuration: Single Ended
 Conversion Rate: 12.5 times/sec (50Hz) or 15 times/sec (60Hz)
 Normal Mode Rejection: NMR 50dB or more (50/60Hz)
 Display: LED, 14.2mm (Red)
 Polarity: A "-" is displayed automatically
 Overrange Indication: When input exceeds the maximum display, display 0L or -0L
 Max. Display: ±9999
 Decimal Point: Settable to any digit position
 Zero Display: Leading zero suppression
 External Control: Hold, Start, Digital Zero, Peak, Valley Hold
 Operating Temp.: 0-50°C 35-85% RH
 Power Supply: AC90-132V
 AC180-264V
 DC 24V±20%(only of DV, DA)
 Power Consumption: Approx. 2.5VA
 Dimensions: 36(H) × 72(W) × 118(D)mm DIN size
 Weight: Approx. 260g
 Dielectric Strength: Input/Earth DC500V
 Input terminals/COM, relay output DC500V
 Power supply/COM, Case, Relay AC1500V/min.
 Insulation Resistance: DC500V 100MΩ at above terminals
 Comparative Control System: Microcomputer
 Setting Range: -9999 to 0 to +9999

Features

- Can change range by front sheet switch
- Conversion rate 12.5 times/sec (50Hz) or 15 times/sec (60Hz)
- Peak hold, Valley hold, Peak-valley hold, digital zero available
- HH, HI, LO, LL setpoints
- Bright LED, 14.2mm (Red)

Comparative Condition: Indication > High high set point→HH
 High high set point ^Indication>High set point→HI
 High set point ^Indication>Low set point→GO
 Low set point ^Indication^Low low set point→LO
 low set point >Indication→LL

Relay Contact Capacity: AC250V 0.2A resistive load
 AC120V 0.5A resistive load
 DC28V 1A resistive load

Photo Coupler output: Sink Current Max. 20mA, less than 1.2V
 Hysteresis: 1-999 digit each set point

External Control: Reset
 Memory Back up: EEPROM

Ordering Code

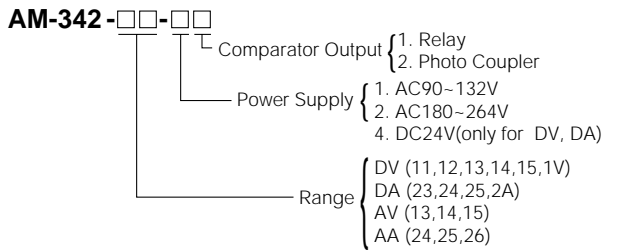

Dimensions

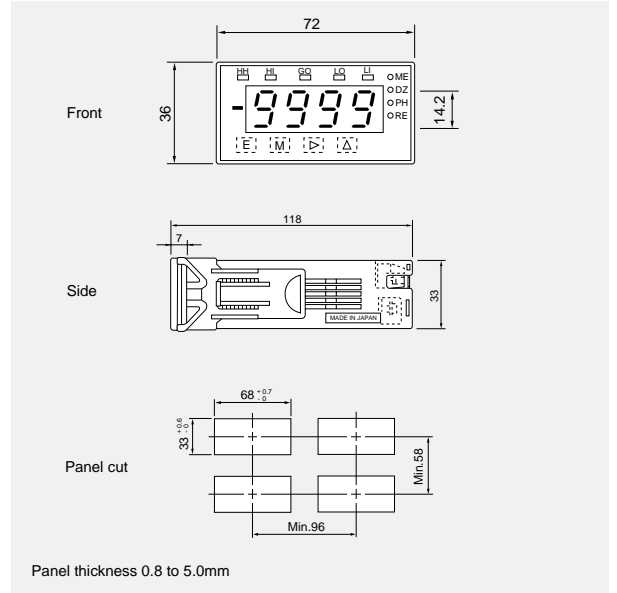

Connection Diagram

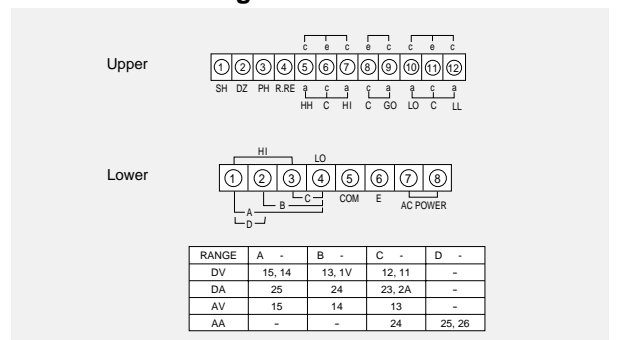

SETPOINT COMPARATOR

AM-346

*RS485, RS232C Output



■ DC Voltage Measurement

Code	Range	Display Adjustable	Input Impedance	Input Protection	
DV	11	±99.99mV	Offset	100MΩ	±250V
	12	±999.9mV		100MΩ	±250V
	13	±9.999V	Fullscale	1MΩ	±250V
	14	±99.99V		10MΩ	±500V
	15	±700.0V		10MΩ	±700V
	1V	1-5V		1MΩ	±250V

Accuracy: ±0.03% rdg ±2 digit (23°C ±5°C)

■ DC Current Measurement

Code	Range	Display Adjustable	Internal Resistance	Input Protection	
DA	23	±9.999mA	Offset	10Ω	±150mA
	24	±99.99mA		1Ω	±500mA
	25	±999.9mA	Fullscale	0.1Ω	±3A
	2A	4-20mA		10Ω	±150mA

Accuracy: ±0.1% rdg ±2 digit (23°C ±5°C)
±0.3% rdg ±2 digit for only 25 range

■ AC Voltage Measurement (TRUE-RMS)

Code	Range	Display Adjustable	Input Impedance	Input Protection	
AV	13	0-9.999V	Offset	1MΩ	300V
	14	0-99.99V		1MΩ	300V
	15	0-700.0V	Fullscale	10MΩ	700V

Accuracy: ±0.3% rdg ±5 digit (23°C ±5°C)

■ AC Current Measurement (TRUE-RMS)

Code	Range	Display Adjustable	Internal Resistance	Input Protection	
AA	24	0-99.99mA	Offset	1Ω	500mA
	25	0-999.9mA		(CT)	10A
	26	0-5.000A	Fullscale	(CT)	10A

Accuracy: ±0.5% rdg ±10 digit (23°C ±5°C)

■ Specifications

• Measuring Section

Input Configuration: Single Ended
Conversion Rate: 12.5 times/sec (50Hz) or 15 times/sec (60Hz)
Normal Mode Rejection: More than NMR 50dB (50/60Hz)
Display: LED, 14.2mm height (Red)
Polarity: A "-" is displayed automatically
Overrange Indication: When input exceeds the maximum display, display OL or -OL

Max. Display: 0 to ±9999

Decimal Point: Settable to any digit position

Zero Display: Leading zero suppression

External Control: Hold ; Shorted COM and S/H terminal or level "0"

Start; Open COM and S/H terminal or "1" level Digital Zero; Shorted COM and DZ terminal or level "0"

Peak Hold;

Valley Hold; Shorted COM and PH terminal or level "0"

Peak Valley Hold;

Level "0" = 0 to 1.5V

Level "1" = 3.5 to 5V

Current = less than -2mA

■ Features

- Compact Size 36X72X118 mm (DIN size)
- Power supply 90 to 132VAC, 180 to 264VAC
- LED height, 14.2mm (Red)
- HH, HI, LO, LL set points available
- Conversion Rate 12.5 times/sec(50Hz), 15 times/sec(60Hz)
- Peak, Valley, Peak-Valley hold (standard)
- Digital Zero
- Output, BCD, ANALOG, RS485, RS232C(option)

• Comparator Section

Control System: Microcomputer

Setting Range: -9999 to +9999 with polarity

Comparative Condition: Indication>High high setpoint

→HH (HI)

High high setpoint≥Indication>High

setpoint →HI

High setpoint≥Indication≥Low

setpoint →GO

Low setpoint>Indication≥Low low

setpoint →LO

Low low setpoint>Indication

→LL (LO)

Photo Coupler Output:

Voltage=Max. 30V

Current=max. 20mA

Saturation voltage=less than 1.2V at 20mA

Hysteresis:

1 to 999 digit each setpoints

External Control:

Reset; Shorted COM and R.RE

terminal or level "0"

Level "0" = 0 to 1.5V

Level "1" = 3.5 to 5V

Current = less than -2mA

• Common Section

Memory Back-up:

EEPROM (Rewrite more than 100,000 times) back up 10 years

0 to 50°C 35 to 85% RH

Operating Temp:

Power Supply:

90 to 132VAC

180 to 264VAC

Power Consumption:

2.5VA TYP. (at 100V)

Dimensions:

36(H) × 72(W) × 118(D) mm DIN Size

Weight:

Approx. 260g (unit only)

Dielectric Strength:

Input/earth, COM, Comparative output, DC500V/ 1 min.

Input/COM of each output terminal, DC500V/1 min.

Power supply/input, COM, case, comparative output, 1500VAC/1 min.

Power supply/COM of each output terminal, 1500VAC/1 min.

Insulation Resistance:

500VDC more than 100MΩ at the above terminals

Dielectric Noise:

Power supply terminal normal/common mode ±1500V Noise width 500nS

Accessories:

Instruction manual, unit label, cover for terminal, setting procedure MIL connector for only BCD and RS232C option

■ Output

● BCD data output (Isolated input (Lo))

• At TTL

Measured Data:

Tri-state parallel BCD, positive logic, latch output

Polarity Signal:

Level "1" at minus input

Over Signal:

Level "1" at overflow input

Printing Command Signal:

Positive pulse approx 20ms at every measurement completion

(Available negative logic the above signals)

TTL level, funout 2, CMOS 5V

SETPOINT COMPARATOR

AM-346

•At Open collector (NPN)

Measured Data: Negative logic transistor "ON" at logic 1
 Polarity Signal: Transistor "ON" at minus input
 Over Signal: Transistor "ON" at overflow input
 Printing Command Signal: Transistor "ON" during a period for approx 20ms at every measurement completion

Transistor Output Capacity: Applied voltage, 30V max. current 10mA max.
 Saturated output voltage less than 1.2V at 10mA

ENABLE: Shorted ENABLE terminal and DG terminal or level "0", Transistor outputs are OFF. (TTL output is high impedance status)
 Level "0"= 0 to 1.5V
 Level "1"= 3.5 to 5V
 Current= less than -0.5mA

●RS-485 (Isolated input (Lo))

Electrical Characteristics: Conforming to EIA RS-485
 Synchronous Method: Start and stop
 Communication Method: 2-wires system half-duplex (Polling and selecting)

Transmission Speed: 2400/4800/9600/19200 bPS

Start Bit: 1 bit
 Data Length: 7 bits
 Error Detection: Even parity (BCC)
 Stop Bit: 2 bits
 Character Code: ASCII code
 Transmission Control: No protocol
 Signal name used:

Signal name	Signal	Signal Direction
Non-reversible output	+	Input/output
Reversible output	-	Input/output

No. of Connectable Meter: Up to 31 meters

Line Length: Up to 500m in total

●RS-232C (Isolated input (Lo))

Electrical Characteristics: Conforming to EIA RS-232C
 Communication Method: Full duplex
 Synchronous Method: Start and Stop
 Transmission Speed: 2400/4600/9600/19200 bPS
 Start Bit: 1 bit
 Data Length: 7 bits
 Error Detection: Even parity
 Stop Bit: 2 bits
 Character Code: ASCII code

●Analog Output (Isolated input (Lo))

Resolution : 13 bits
 Output Response: Less than 0.5S

Output	Resistive load	Accuracy(23°C±5°C)	Ripple
0 to 10V	More than 10K	±0.5% FS	50mV P-P
4 to 20mA	0 to 550	±0.5% FS	less than 0.5%

*Ripple for 4 to 20mA at resistive load 250 , 20mA

■ Ordering Code

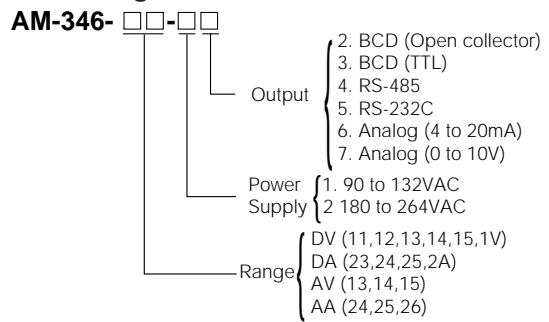

■ Dimensions

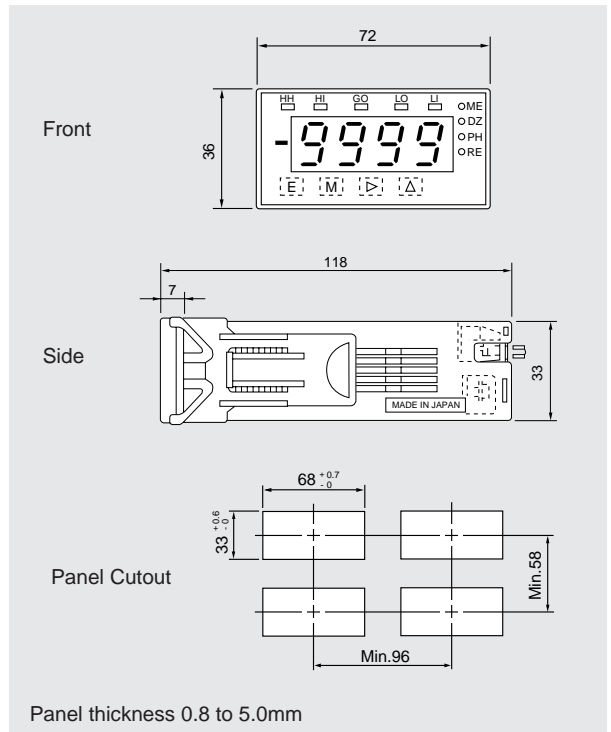

■ Connection Diagram

